

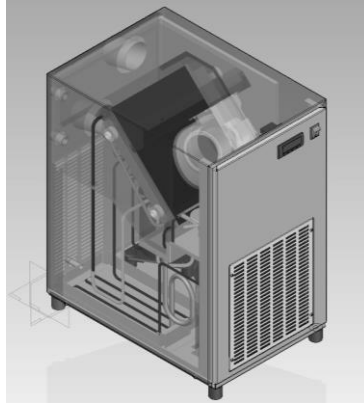

SAFETYFIRST



CUBETTO®

Data Sheet

**CONTROLLED COOLING KIT
FOR SAFETY CABINETS SAFETYBOX® FLAMMABLES**

DESCRIPTION

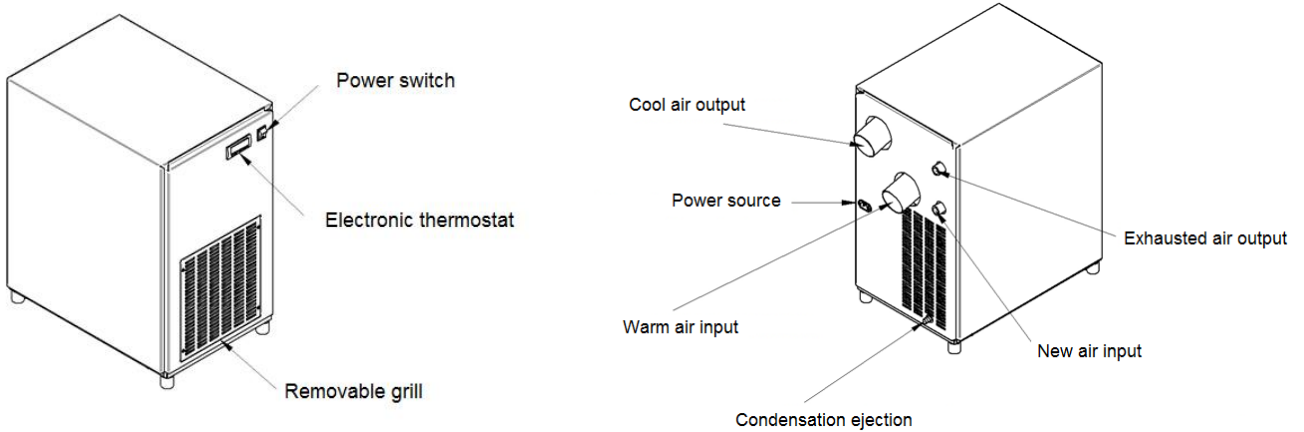

DIMENSIONS

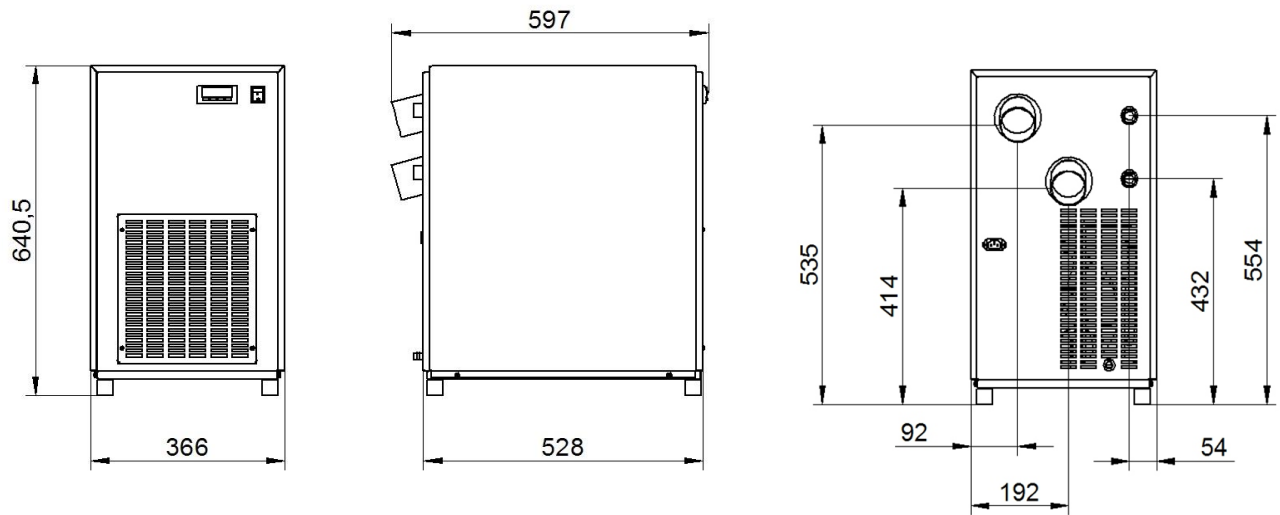

TECHNICAL SPECIFICATIONS

	U.M.	
Nominal cooling power	kW	1,4
Total absorbed power	W	480
Maximum absorbed power	W	520
Maximum power	A	2,4
Power source	V/HZ/Ph	230/50/1
Compressor type		Revolving
Compressors	Nr	1
Refrigeration power (R410a)	Kg	0,3
Heat Exchanger type		Finned batteries
Heat exchangers	Nr	2
Cooled air flow	m ³ /h	170
Predominance	Pa	130
Predominance (with activated charcoal filter)	Pa	110
Sound pressure level	dB(A)	47
Max. environmental temperature	°C	36
Min. temperature setting	°C	8
Treated air joints	mm	ø70
New air joints		1/2"(F)
Condensation ejection joint	mm	ø14
Weight	Kg	39

Expansion vessel	Liters	2
Width	mm	366
Height	mm	641
Depth	mm	597